

# MT Series

## Matrix Turret Rewinder

### Overview

The MT is designed to mount over a press and eliminates press stops for removal of matrix waste. Combined with a KTI butt splicer and turret rewinder, the MT is the final step to a non-stop label press.

### Standard Features

- Automatic transfer to new core at programmed roll diameter
- Automatic speed matched transfer at process line speed
- Two spindle configuration
- Non-stick plasma coated idler rollers
- Taper or linear winding tension
- Reduces loss of climate controlled air typical with vacuum systems
- PLC Controls with touch screen
- Remote diagnostics ready

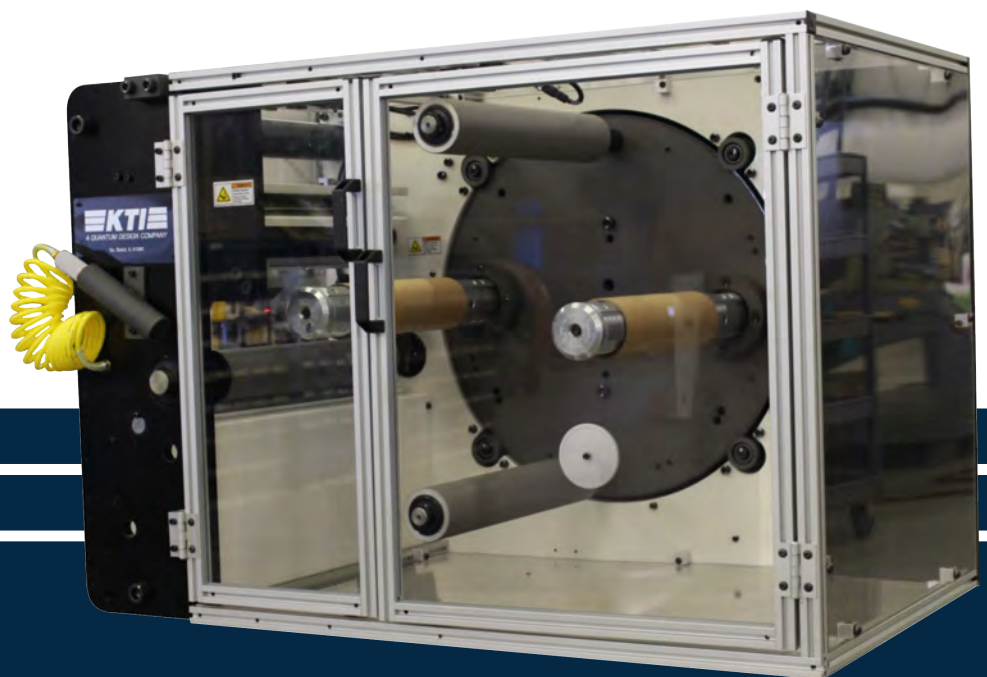

[www.ktiusa.com](http://www.ktiusa.com)

# MT Series

## Matrix Turret Rewinder

### Options

- Lay-on roller for non-uniform label shapes

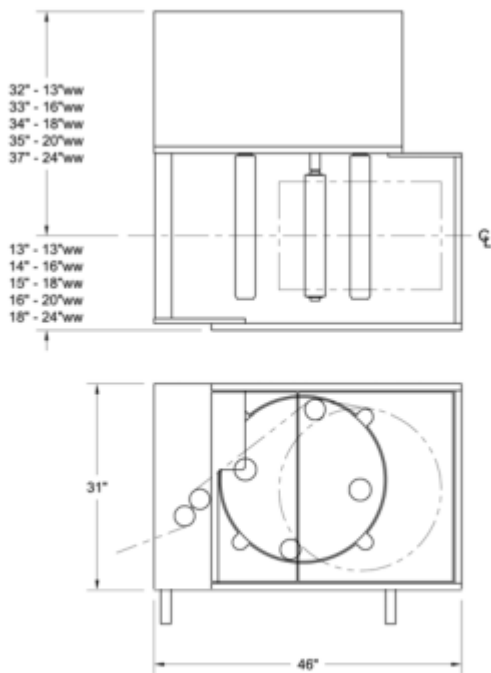

MT MATRIX TURRET REWINDER

DIMENSIONS SUBJECT TO CHANGE WITHOUT NOTICE



## Specifications

- Web Width** • Up to 24 inch (609mm)
- Roll Diameter** • Up to 24 inch (609mm)
- Roll Weight** • Up to 50 lbs (22 kg)
- Transfer Speed** • Up to 750 FPM (228 MPM)
- Core Size** • 3 inch (76mm)

### Materials

Waste matrix from pressure sensitive label stock

## KTI, A Quantum Design Product Line

14357 Commerical Parkway • South Beloit, IL 61080

**P** (815) 624-8989 • **F** (815) 624-4223

**Web** [www.ktiusa.com](http://www.ktiusa.com) • **Email** [info@ktiusa.com](mailto:info@ktiusa.com)