

# RW Series

## Single Position Rewinds

### Overview

This single position rewind offers a safety conscious design and provides a combination of high performance and robust construction. Available in cantilever and shafted designs, this cost-effective machine is easily integrated into any press production.

### Standard Features

- Safety conscious designs
- Automatic process stop for web breaks
- Automatic process stop at pre-determined roll diameter
- Bi-directional capability
- Integrated hoist on shafted design
- PLC controls with touch screen



# RW Series

## Single Position Rewinds

### Options

- Roll loading cart – cantilever style
- Remote diagnostics ready

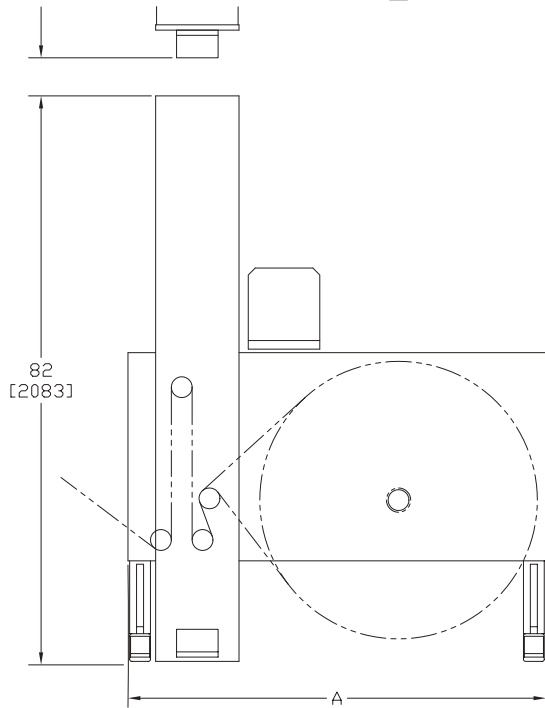

MODEL PC1424-R

DIMENSIONS SUBJECT TO CHANGE WITHOUT NOTICE

## Specifications

**Web Width** • Up to 27 inch (685 mm)

**Roll Diameter** • Up to 50 Inch (1270 mm)

**Roll Weight** • Up to 1800 lbs (816 kg)

**Speed** • Up to 1000 FPM (304 mpm)

**Core Size** • 3 Inch

### Materials

Paper

Labels

Tags

Specialty Materials

### KTI, A Quantum Design Product Line

14357 Commerical Parkway South Beloit, IL 61080

**P** (815) 624-8989 • **F** (815) 624-4223

**Web** [www.ktiusa.com](http://www.ktiusa.com) • **Email** [info@ktiusa.com](mailto:info@ktiusa.com)