

UW Series

Single Position Unwind

Overview

The UW was designed with safety in mind and is available in cantilever and shafted designs. The dancer roller offers adjustable tension control. This machine is easy to integrate and use and provides a combination of high performance and robust construction.

Standard Features

- Safety conscious design
- Automatic process stop for web breaks
- Automatic process stop at pre-determined roll diameter
- Dancer roller with adjustable tension control
- Manual side lay adjustment
- Bi-directional unwind capability
- Integrated hoist on shafted design
- PLC Controls with touch screen



UW Series

Single Position Unwind

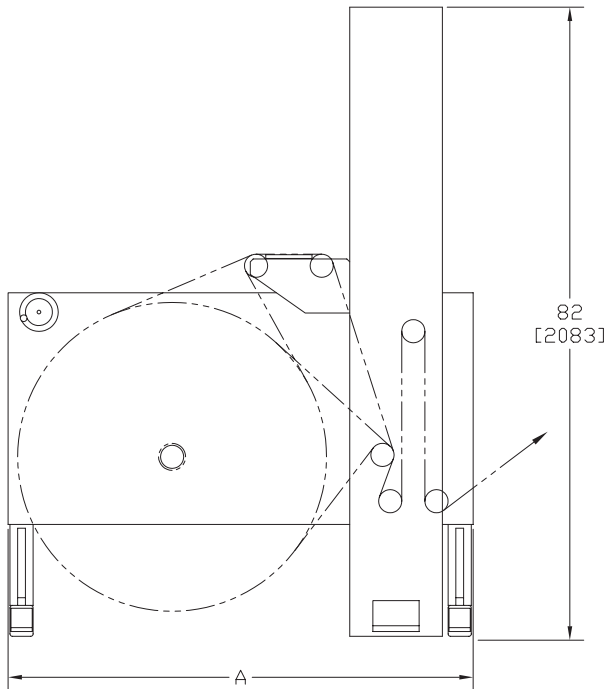

Options

- Integrated manual splice table
- Automatic decurler
- Roll loading cart - cantilever style
- Remote diagnostics ready

Specifications

Web Width • Up to 27 inch (685mm)
Roll Diameter • Up to 50 inch (1270mm)
Roll Weight • Up to 1800 lbs (816 kg)
Speed • Up to 1000 FPM (304 MPM)
Core Size • 3 inch

Materials

Paper
Label
Tag
Specialty Materials

KTI, A Quantum Design Product Line

14357 Commerical Parkway • South Beloit, IL 61080

P (815) 624-8989 • **F** (815) 624-4223

Web www.ktiusa.com • **Email** info@ktiusa.com