

UWD Series

Single Position Driven Unwind

Overview

The UWD is designed for use with KTI turret rewinders to create a complete, stand alone, off-line finishing system. The machine is easy to integrate and use with existing KTI equipment and provides a combination of high performance and robust construction.

Standard Features

- Cantilevered pneumatic spindle
- Automatic stop at end of roll
- Drive feed roller with nip
- Bi-directional unwind capability
- PLC Controls with touch screen

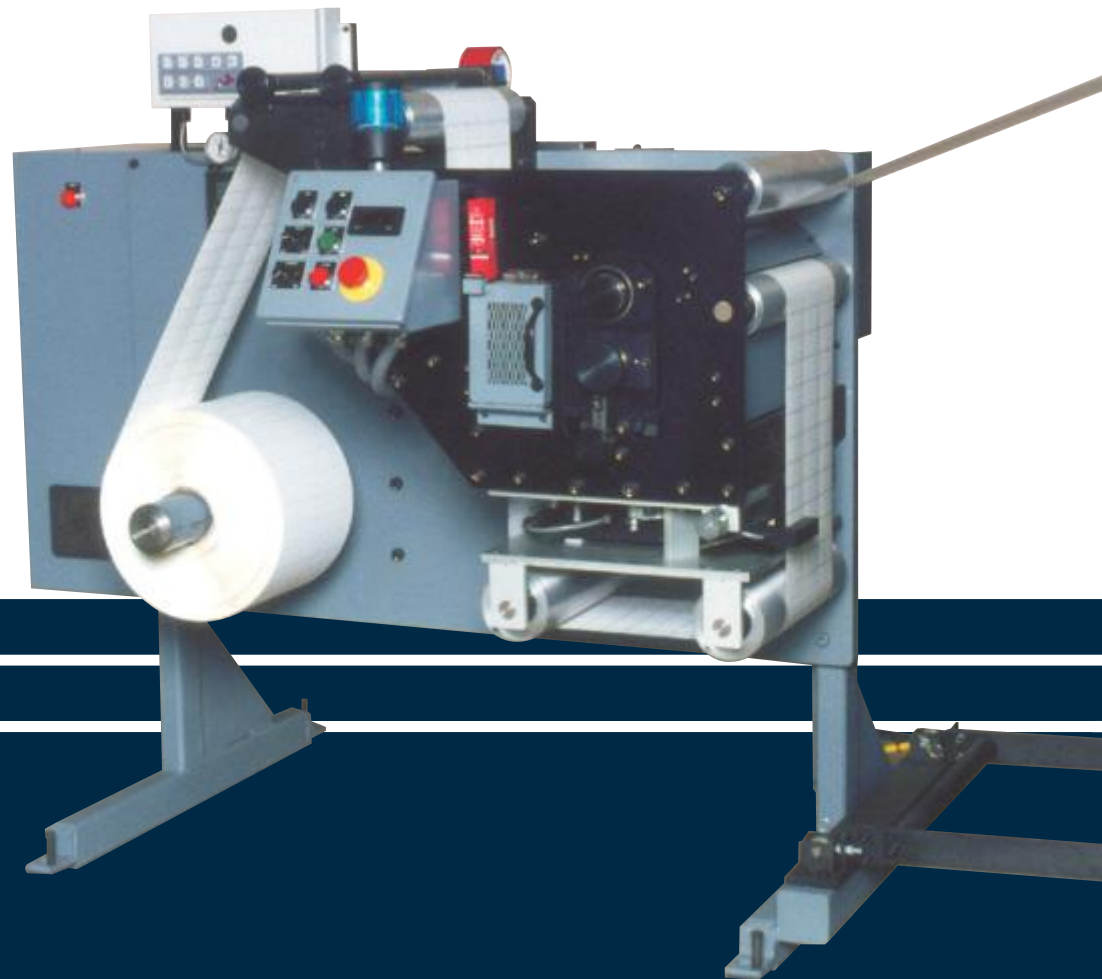

www.ktiusa.com

UWD Series

Single Position Driven

Unwind

Options

- Integrated manual splice table
- Casters
- Roll loading cart
- Remote diagnostics ready

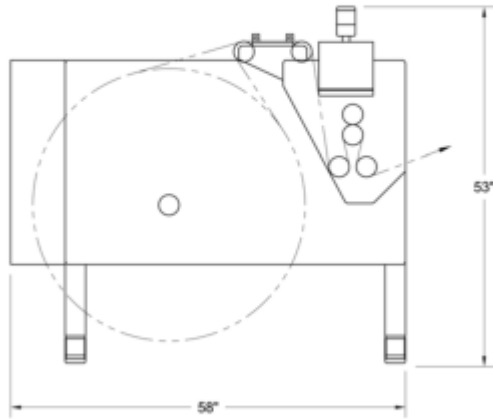

MODEL UWD1340-05

DIMENSIONS SUBJECT TO CHANGE WITHOUT NOTICE

Specifications

Web Width • Up to 22 inch (558mm)
Roll Diameter • Up to 40 inch (1016mm)
Roll Weight • Up to 1000 lbs (453 kg)
Running Speed • Up to 750 FPM (228 MPM)
Core Size • 3 inch (76mm)

Materials

Die cut PS labels

KTI, A Quantum Design Product Line

7550 Quantum Court • Caledonia, IL 61011

P (815) 885-1300 • **F** (815) 885-1370

Web www.ktiusa.com • **Email** info@ktiusa.com